

# NORTHSTAR<sup>+</sup> AXIS 3.4

## Specifications

Length	340 cm. / 11'2"
Beam	175 cm. / 5'9"
Weight	210 kg. / 462 lbs
Tube Diameter	0.41 m. / 16.1"
Suggested Tube Pressure	0.18 bar / 2.6 psi
No. of Chambers	3
Maximum Persons	4
Minimum Power	25 HP
Maximum Power	40 HP
Recommended Power	30 HP
Shaft Length	L
Fuel Tank Capacity	33 lt. / 8.7 US Gal
Design Category	CE - Cat. C

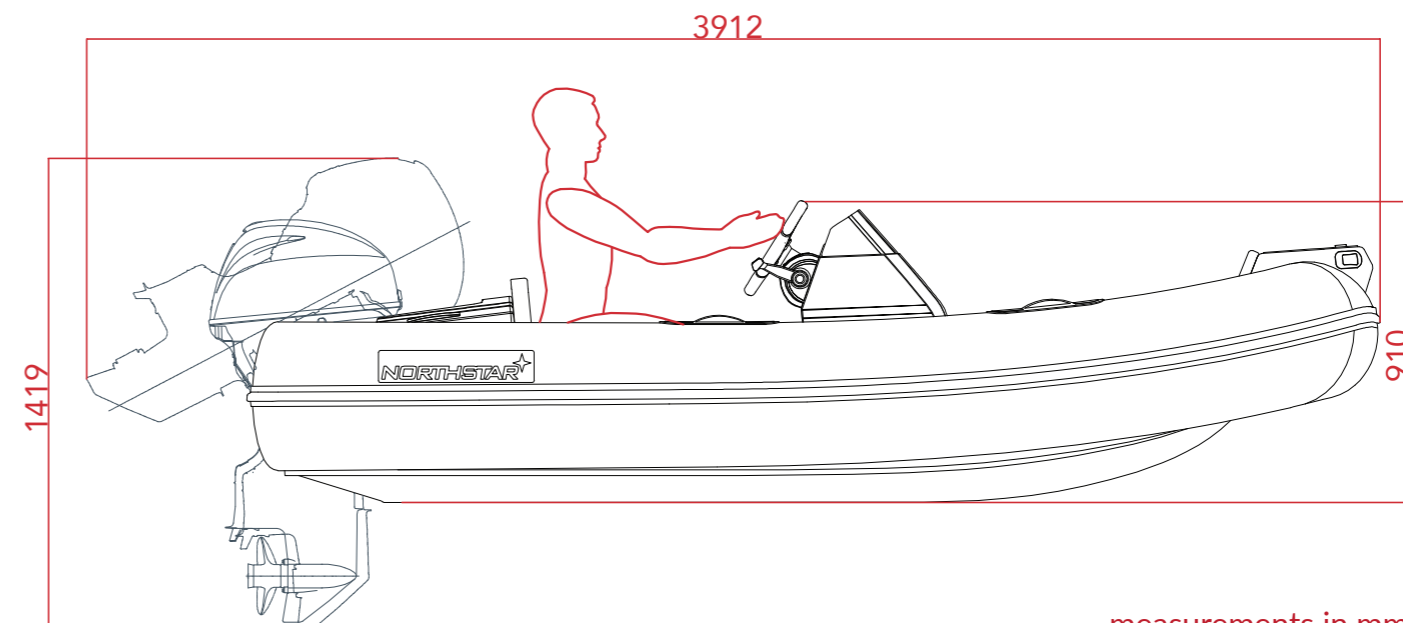
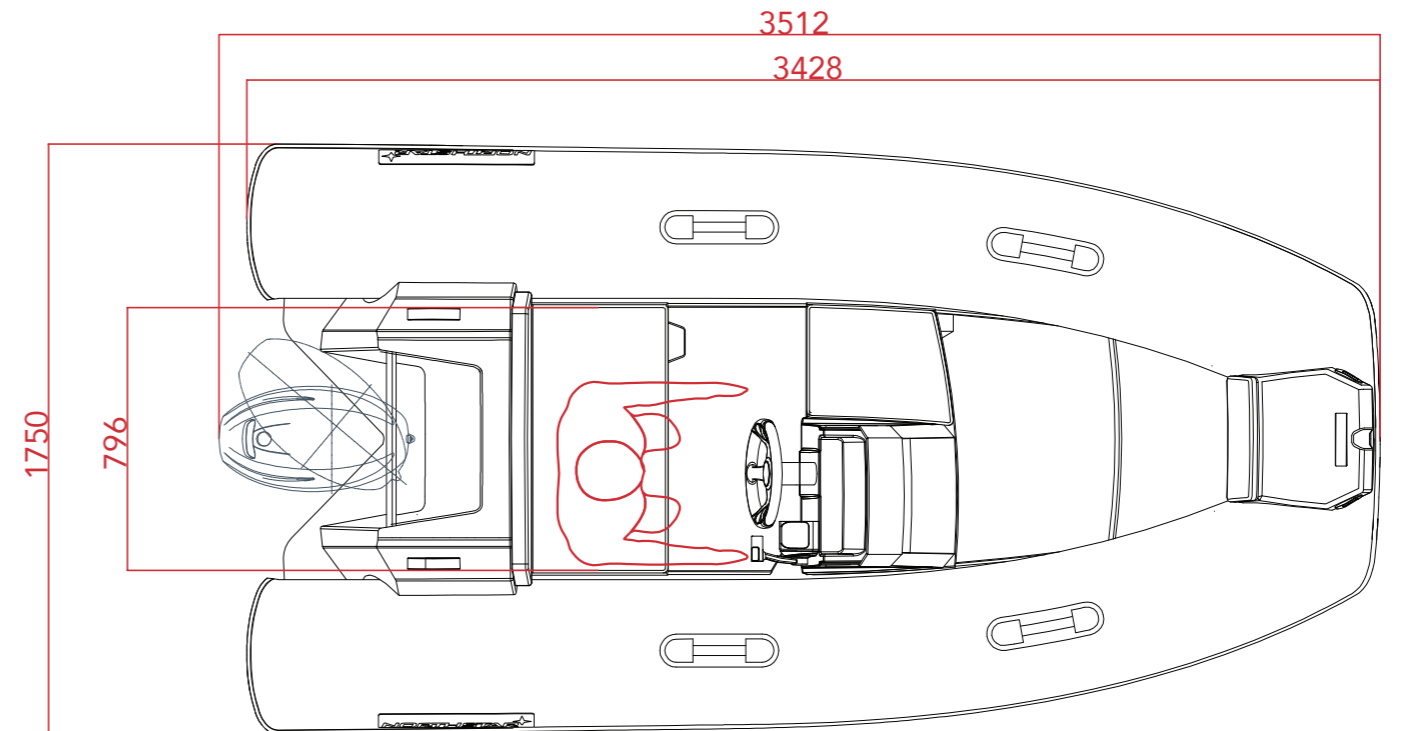

measurements in mm