

NORTHSTAR⁺ AXIS 4.2

Specifications

Length	425 cm. / 13'9"
Beam	196 cm. / 6'5"
Weight	282 kg. / 621 lbs
Tube Diameter	0.43 m. / 16.9"
Suggested Tube Pressure	0.18 bar / 2.6 psi
No. of Chambers	4
Maximum Persons	6
Minimum Power	40 HP
Maximum Power	60 HP
Recommended Power	50 HP
Shaft Length	L
Fuel Tank Capacity	42 lt. / 11.1 US Gal
Design Category	CE - Cat. C

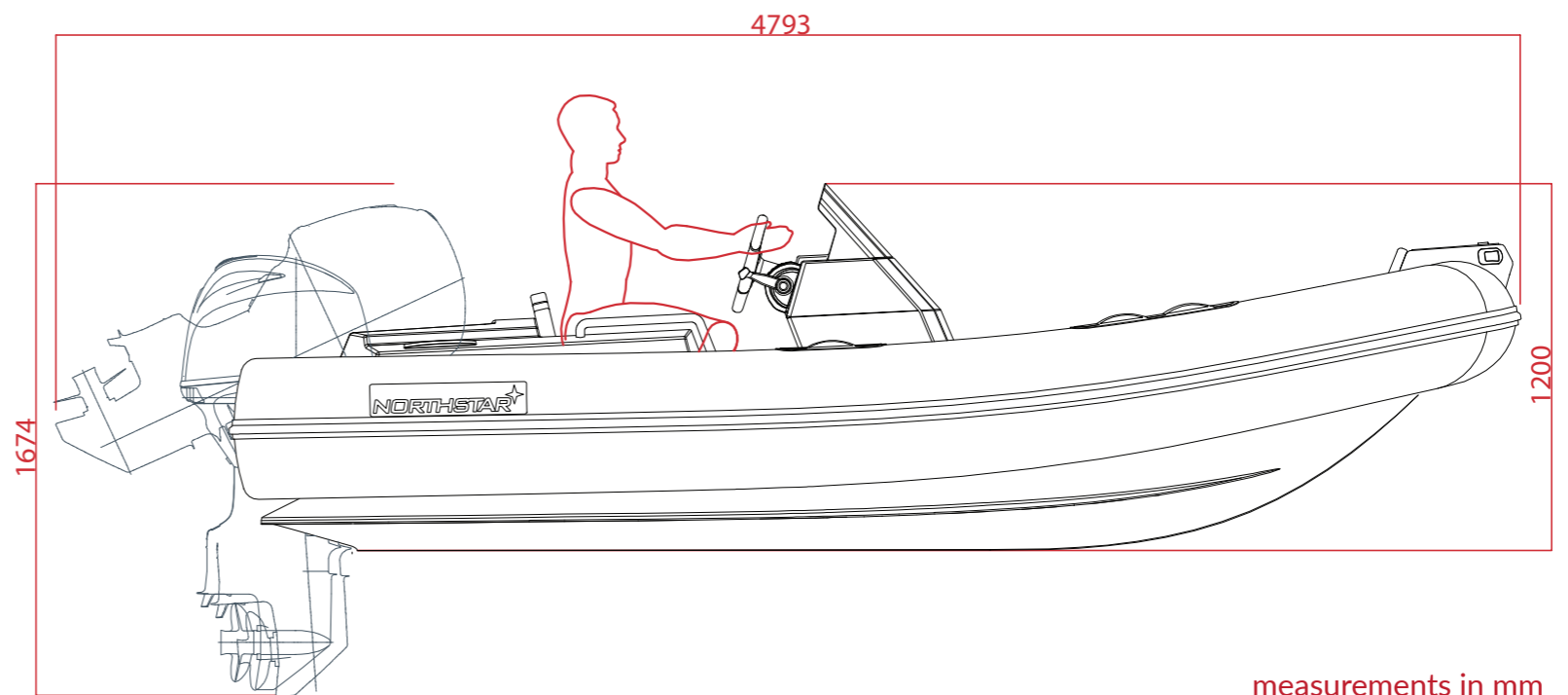
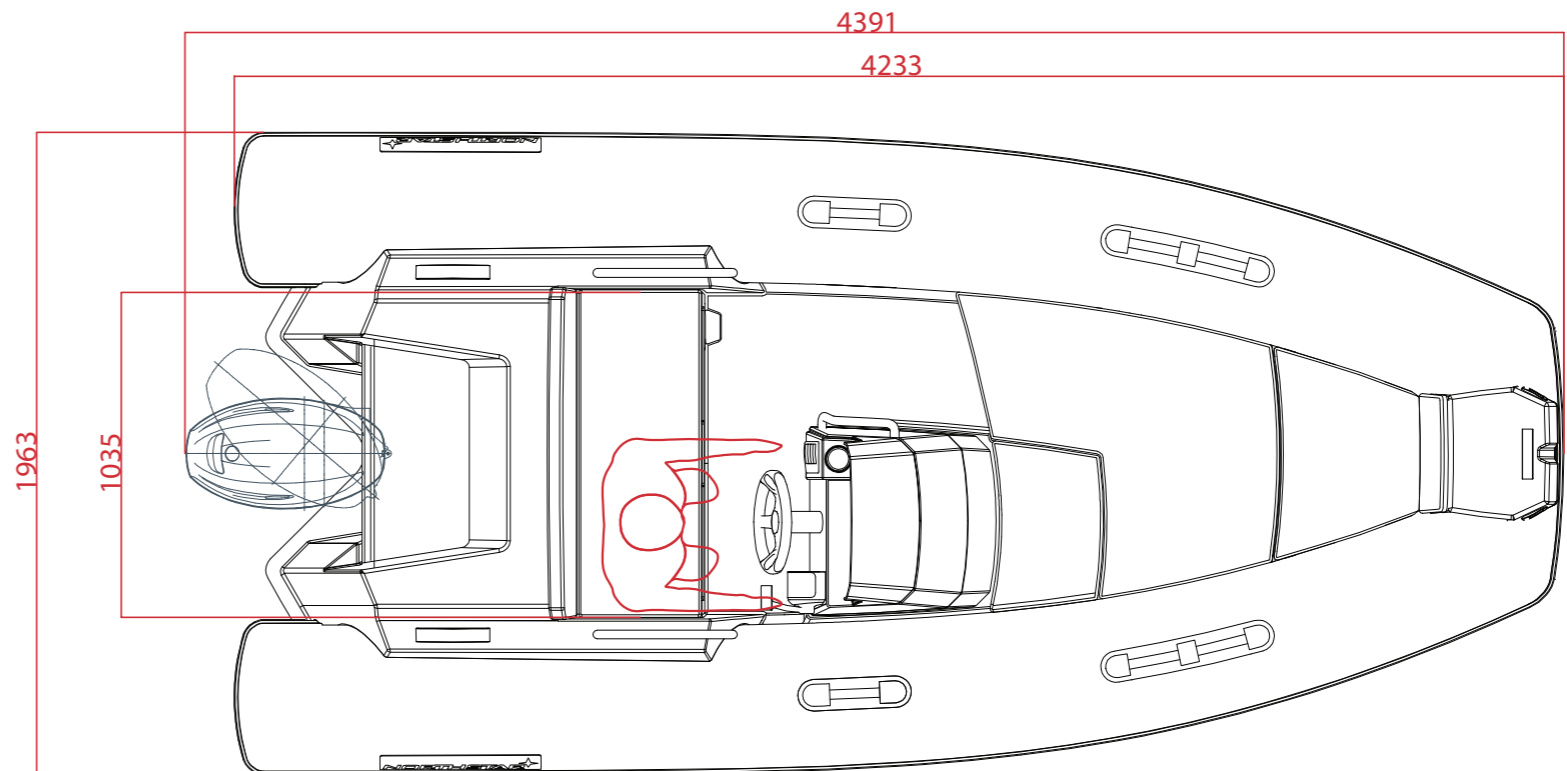

measurements in mm